

INSTALLATION GUIDE

AMP RESEARCH Power Step MADE IN USA

APPLICATION	MODEL YR	PART #
Chevrolet Silverado / GMC Sierra	1999–2006 (Crew Cab)	75113-01A
	(Extended Cab)	75113-01A
Chevrolet Tahoe / Suburban	2001-2006	75115-01A
Chevrolet Avalanche	(without cladding)	75115-01A
	(with cladding)	75114-01A
GMC Yukon / Yukon XL	2001-2006	75115-01A
Cadillac Escalade Ext / ESV	2003–2006	75115-01A

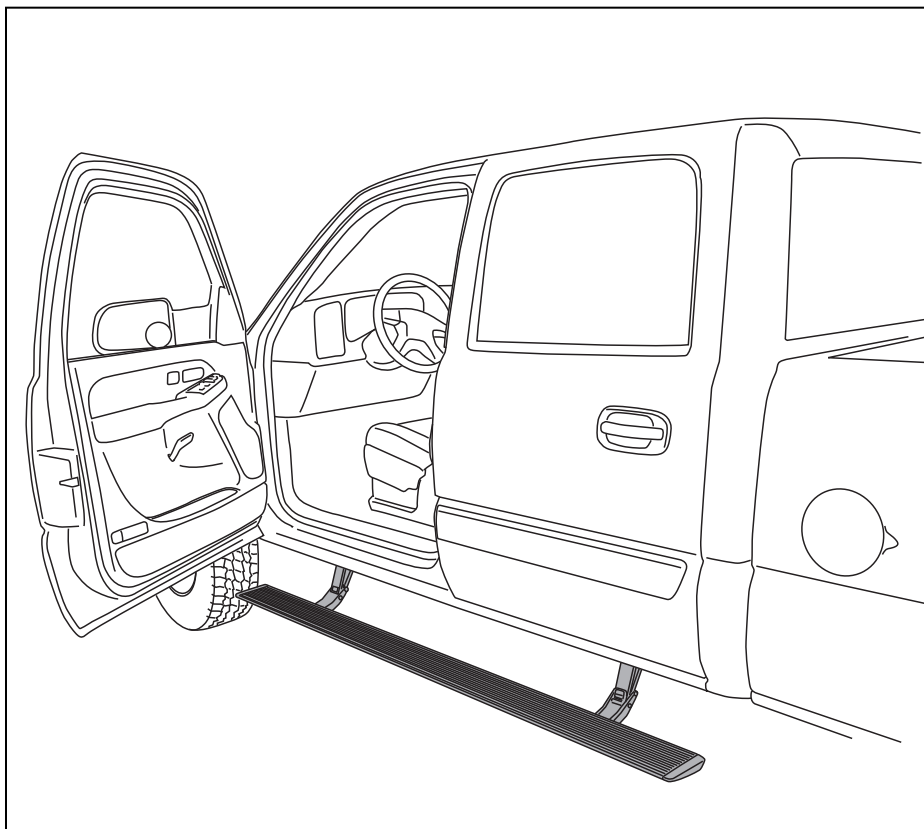

INSTALLATION TIME

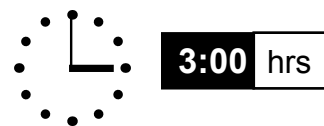

SKILL LEVEL



TOOLS REQUIRED

- Safety goggles
- Measuring tape
- Flat blade screwdriver
- Phillips head screwdriver
- Right angle drill
- 1/8" drill bit 3/16" drill bit
- 9/32" drill bit 21/64" drill bit
- 17mm socket
- 13 mm socket
- 10 mm socket 7 mm socket
- T 20 Torx driver
- Ratchet wrench and extension
- 13mm end wrench
- Wire crimpers
- Wire stripper / cutter
- Vise grip pliers
- Corrosion inhibitor
- 3/16" hex key wrench (allen wrench)
- 5mm hex key wrench (allen wrench)
- 4mm hex key wrench (allen wrench)
- Electrical tape
- Weather proof caulking (silicone sealer)

AMP RESEARCH TECH SUPPORT 1-888-983-2204 (Press 2) Monday - Friday, 6:00 AM - 5:00 PM PST

Designed and manufactured by AMP Research®. Patent Number 6,830,257; 6,641,158; 6,834,875; 6,938,909; 6,942,233; 7,007,961; 7,055,839; 7,163,221; 7,367,574; 7,380,807; 7,398,985; 7,413,204; 7,487,986. Other US and Worldwide patents pending. Made in USA © 2010 AMP Research
5-year limited warranty. Professional installation is recommended.

INSTALLATION GUIDE

INSTALLATION GUIDE

Attaching motor to linkage assembly

The motors must be attached to the linkage assemblies before continuing the installation process.

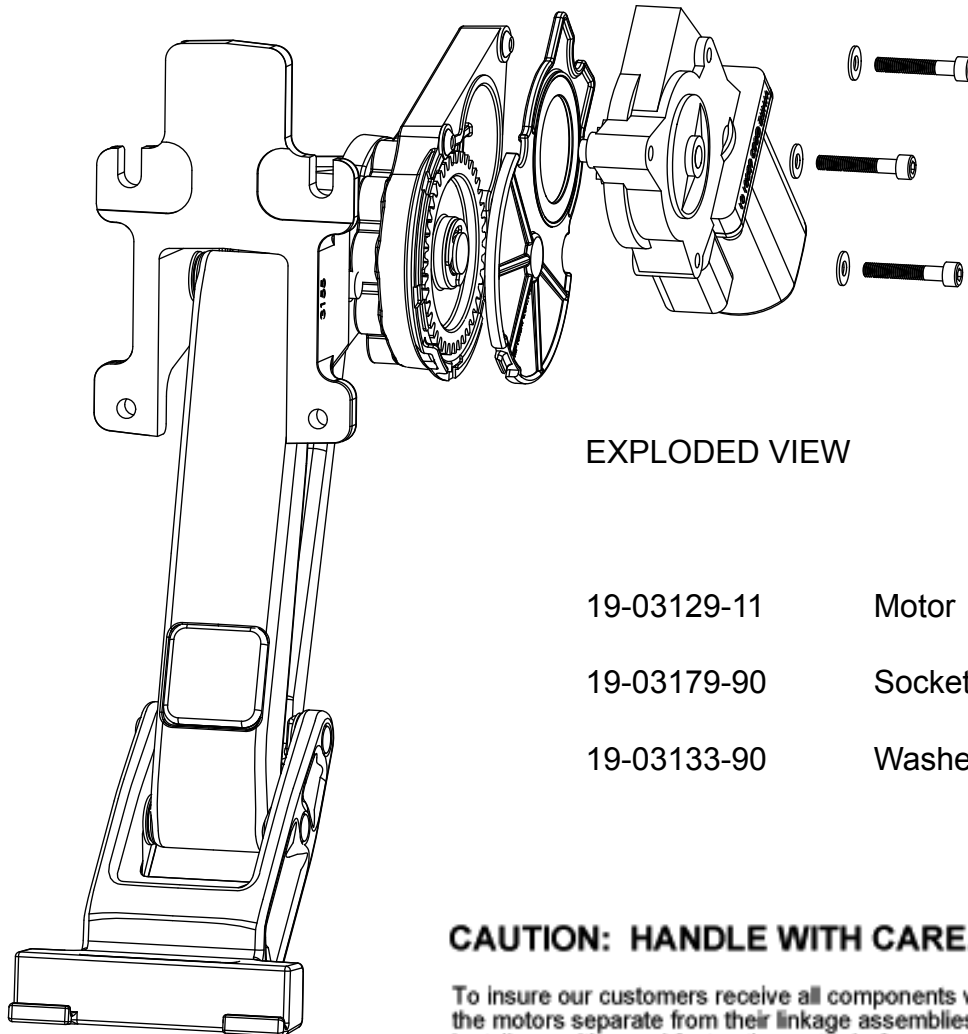

EXPLODED VIEW

19-03129-11	Motor
19-03179-90	Socket cap screw
19-03133-90	Washer

CAUTION: HANDLE WITH CARE.

To insure our customers receive all components with full integrity, we pack the motors separate from their linkage assemblies. This requires that the installer position and fasten the motor before continuing with the install. Please follow the instructions below and handle the assembly carefully.

CAUTION: Dropping the assembly or any excessive impact MAY cause damage to the motor.

Instructions:

1. Position the gear cover in place as shown if not already in place.
2. Seat motor into position on the three mounting bosses. The motor mounts will sit flush to all three mounting bosses. This may require an adjustment of the gear by moving the swing arms.
3. After seating into place, fasten the motor with the three motor mount screws with T30 Torx. Tighten screws to 80 in-lbs (9N-m). Do not over torque.

INSTALLATION GUIDE

Note: Some Applications require modification.

Application	Cut Length
Crew Cab	79" (No Modification Required)
Extended Cab	72" (Trim 7")

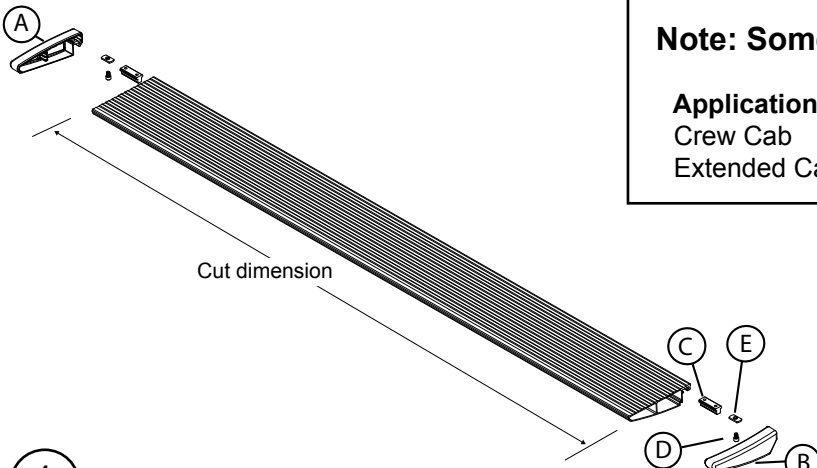

1 x2
20-03314-XX
Running board assembly

(A) 19-03225-11 End cap left (x1)
(B) 19-03225-12 End cap right (x1)
(C) 19-02663-90 T-nut insert (x2)
(D) 19-03236-90 Socket cap screw (x2)
(E) 19-03237-90 Nut plate (x2)

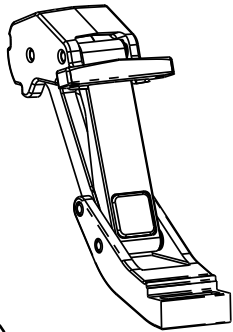

2 (x2-03058-11 Shown)
10-03035-10 SUV
10-03058-11 Truck
Idler linkage assembly

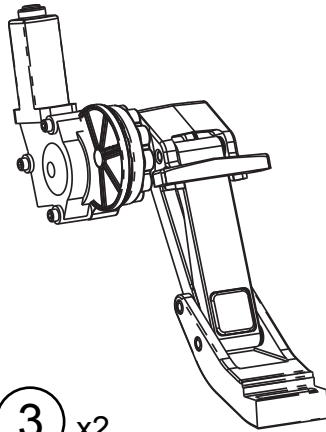

3 x2
10-03034-11 SUV
10-03059-12 Truck
Motor linkage assembly

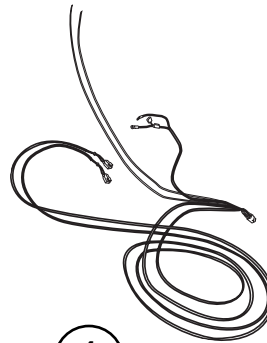

4
19-03067-93 SUV
19-03067-91 Truck
Wire harness

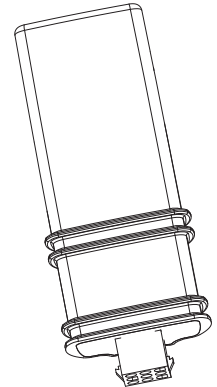

5
19-03297-93
Controller

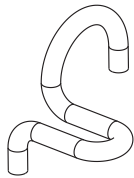

USED ON SILVERADO
AND SIERRA
HEAVY DUTIES ONLY.

6 x2
16-03079-90
Cable Bracket



USED ON SILVERADO
AND SIERRA
HEAVY DUTIES ONLY.

7
19-03088-90
Brake Cable Ring

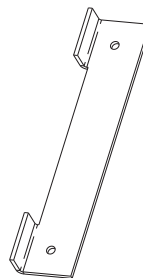

8
19-03044-90
Drill Template

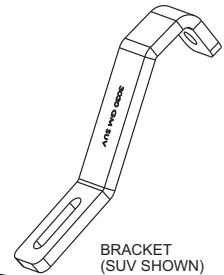

BRACKET
(SUV SHOWN)

9 x4
16-03055-90-TRUCK
Mounting Bracket
19-03149-90-SUV
Mounting Bracket

INSTALLATION GUIDE

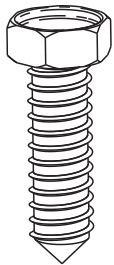

10 x8
19-02812-90
Hex Head
Sheet Metal Screw

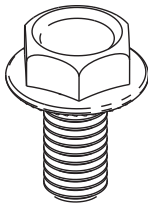

11 x4
19-03037-90 SUV
19-03248-90 Truck
Hex Flange Bolt

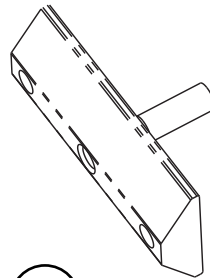

12 x4
19-03032-90
Upper Sill Mount
with 19-03033-90
Stud

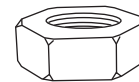

13 x4
10-00115-60
Nylock Nut

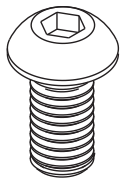

14 x8
19-02634-90
Button Head Bolt

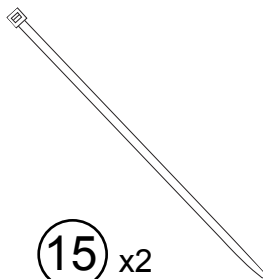

15 x2
19-03339-90
Cable tie (11")

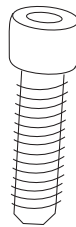

16 x8
19-02802-90
Socket Cap Screw

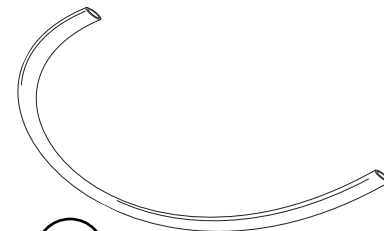

17
19-02992-90
Tubing (Installation Tool)

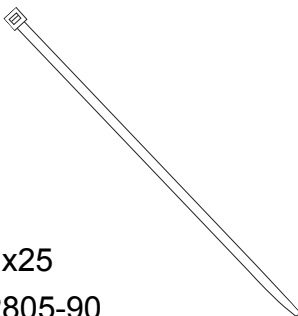

18 x25
19-02805-90
Cable tie (7")

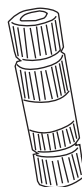

19 x4
19-03354-90
Posi-Tap™ (Red/Grey)

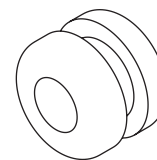

20
19-02640-90
Grommet



21 x8
19-03021-90
Hex Nut
(for Truck only- Step 8)

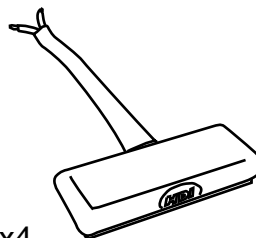

22 x4
80-03302-90
LED Lamp



23 x8
19-02989-90
Butt Connector

INSTALLATION GUIDE

Steps 1-3 for Heavy Duty Trucks only! For all other vehicles skip to Step 4.

HD - Short Bed: Remove forward most brake cable guide.

HD - Long Bed: Remove first and third brake cable guide.

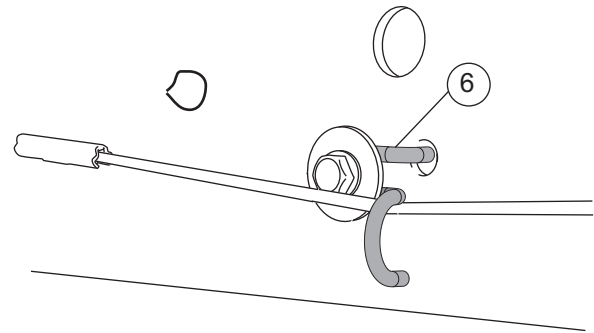

1

2

Install replacement brake cable guides.

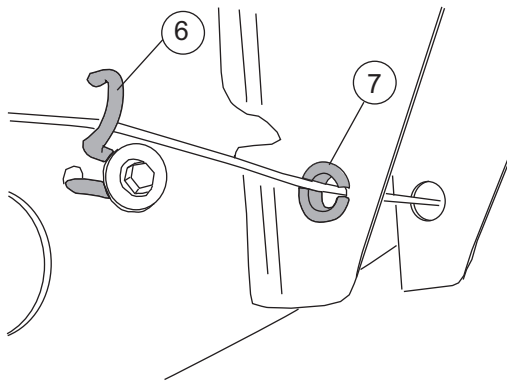

HD - Long Bed: Install plastic brake cable guide in forward hole of rear body mount.

3

Rear linkage assembly. Template position for Tahoe and Yukon shown in hidden lines.

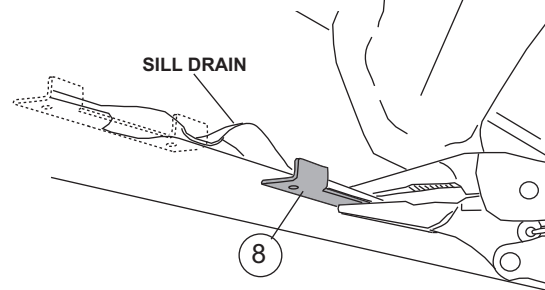

Clamp drill template about 1/16" forward of the rearmost sill drain.

4

Tahoe and Yukon: Clamp Template 1/8" behind second rearmost sill drain.

With drill template secured with vise grips, drill 1/8" starter holes. Remove template and drill holes to 21/64".

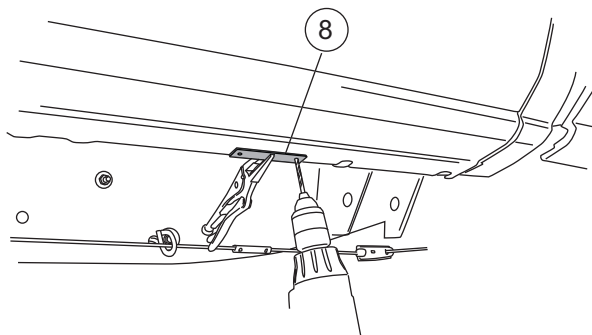

5

Tahoe and Yukon: Clamp Template 1/8" behind second rearmost sill drain.

Front linkage assembly. Template position for SUV driver side shown in hidden lines.

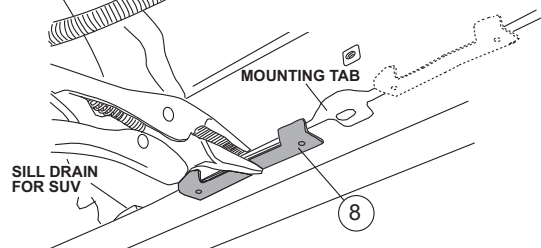

Clamp drill template to pinch weld about 1/8" behind the forward most mounting tab.

Then repeat Step 5.

SUV's: On driver side only, clamp template 1/8" in front of forward most mounting tab.

6

INSTALLATION GUIDE

CAUTION: Remove step plates on inside of cab and move vehicle wire harnesses out of the way before drilling in Steps 8 & 9.

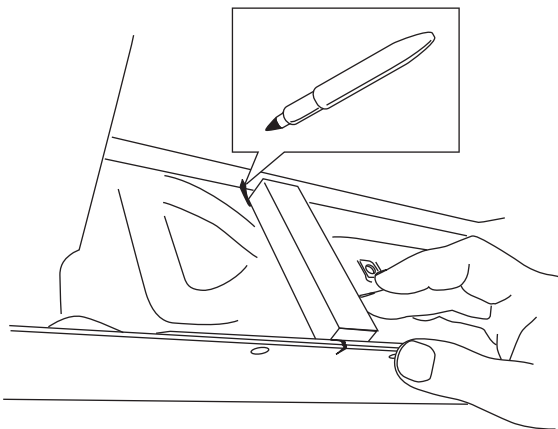

7 Use a straight edge to make a vertical line centered between drilled mounting holes.

READ THE ABOVE CAUTION NOTE!
Center the upper support mount and drill 1/8" starter holes, then remove mount and drill 3/16" holes. Drill through first layer of sheet metal only. Attach with #14 sheet metal screws.

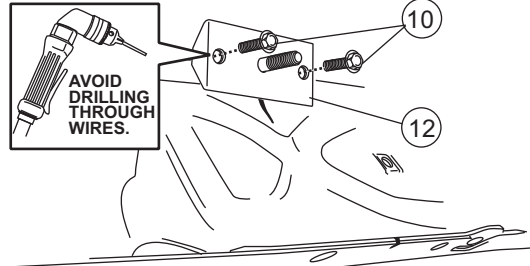

8 File down any exposed screw tips from inside and cover with silicone.

READ CAUTION NOTE AT TOP OF PAGE!
Repeat Steps 7 & 8 for rear mount. Drill through first layer of sheet metal only. This mount support will mount partially behind frame support and will require only one sheet metal screw.

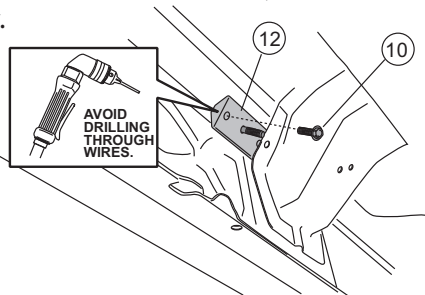

9 File down any exposed screw tips from inside and cover with silicone.

Mount linkage assembly and upper bracket and finger tighten all fasteners.

IMPORTANT NOTE:

For Truck and HD Avalanche:
The motorized linkage assembly goes to the front location on the drivers side and to the rear location on the passenger side.

For SUV & 1500 Avalanche:
The motorized linkage assembly goes towards the front on both sides.

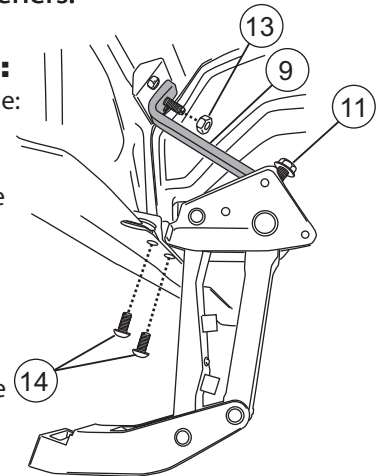

10

Slide mounting T-nut into position. Mount board and tighten fasteners to 10 ft-lbs. Align the end of the board with the rear edge of the back door.

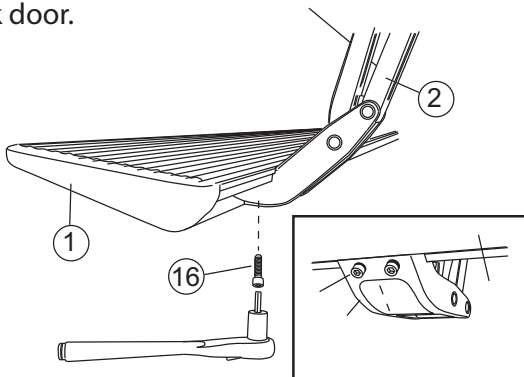

11

Tighten button head fasteners and upper nut to 16 ft-lbs. Then adjust the bottom edge to horizontal and tighten hex bolt to 16ft-lbs.

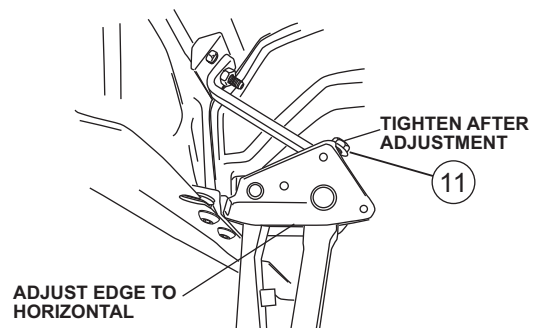

12

INSTALLATION GUIDE

Using the two 11" cable ties, mount controller to factory wire conduit above brake booster on drivers side of truck.

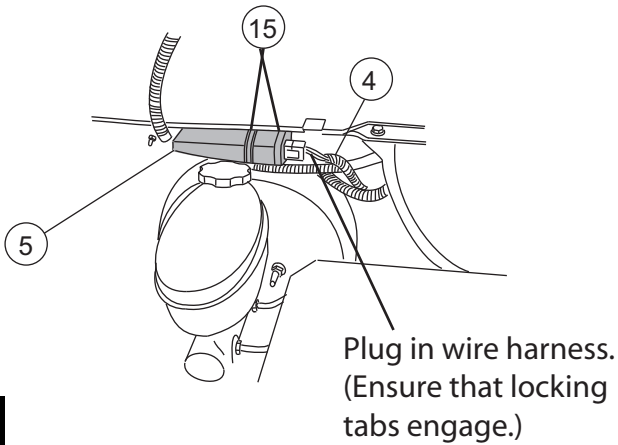

Remove power fuse. Attach power lead RED wire to positive lead in the junction box. CAUTION: Do not ground wrench when engaged with nut.

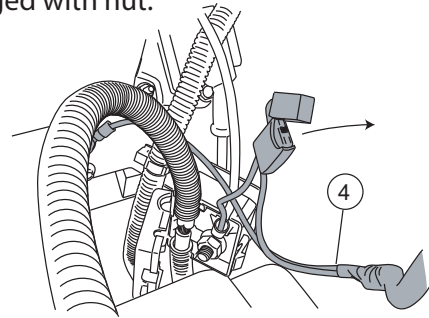

13

14

Route long end of wire harness above engine and down through passenger side wheel well. Zip tie harness to cowling clips on fire wall. Route short end down drivers side.

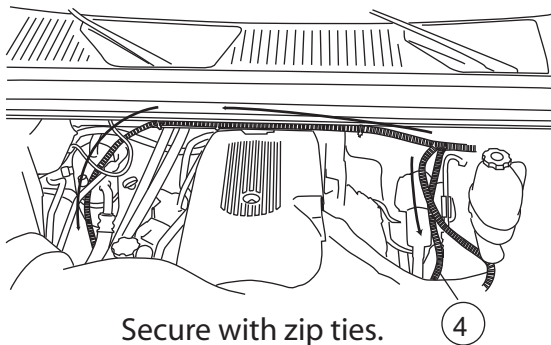

Route wire harness along the frame. Secure with zip ties.

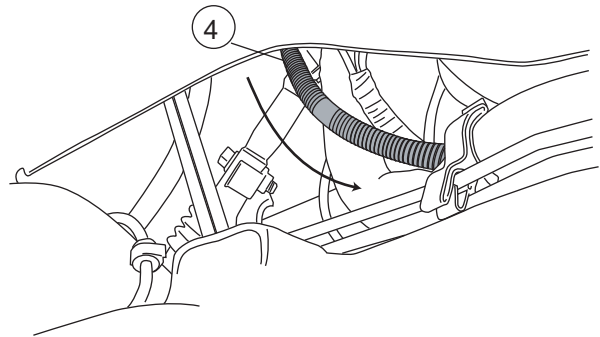

15

16

Poke hole through rubber grommet near front door on underside of floor panel with small phillips screwdriver. Push both wires through hole. (See Step 19 for passenger side notes.)

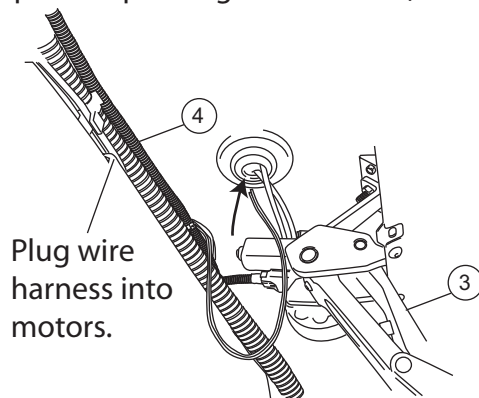

Pop off the threshold cover with screwdriver and remove the kick panel. The panel will slide out from under the seat after fasteners give way.

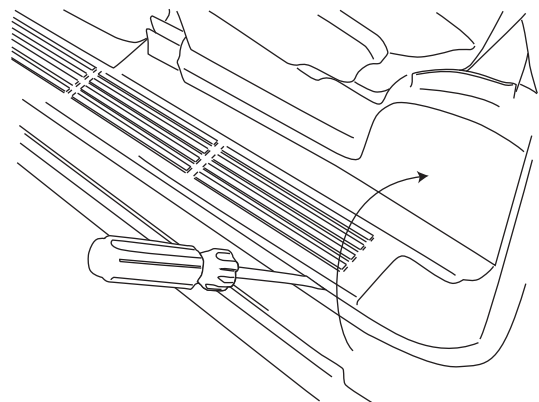

17

18

INSTALLATION GUIDE

IMPORTANT: Steps 20 and 21 are for Crew Cabs and SUV's only. Light blue and Green wires will not be used otherwise. See wire diagrams for model years previous to 2003.

Pull up the carpet and thread both wires through the floor panel (same steps on passenger side EXCEPT drill 9/32" hole in metal and add rubber grommet).

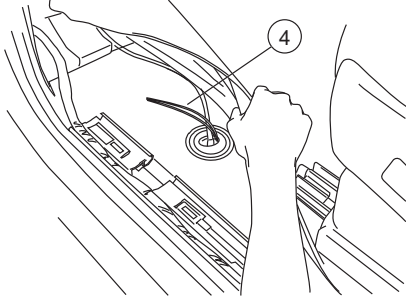

19 Seal holes with silicone glue.

On Crew Cab's and SUV's carefully remove wire wrap and find LIGHT BLUE wire with BLACK STRIPE (on passenger side find GREEN wire with BLACK STRIPE rear of the "T" junction where wires cross under the front seat).

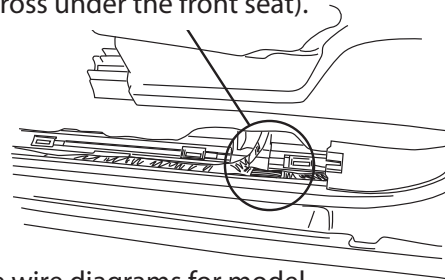

20 See wire diagrams for model years previous to 2003.

Using supplied Posi-Taps™ splice shorter trigger wire into wire found in step 20.

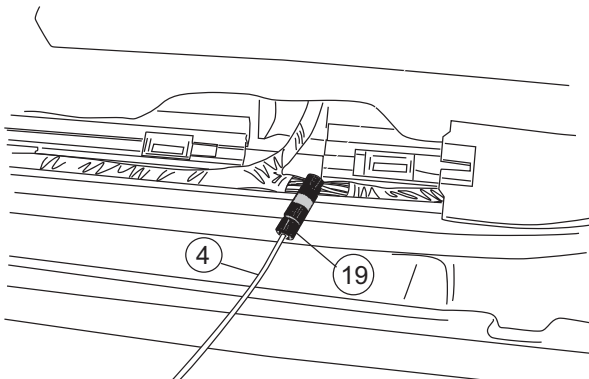

21 Note: Crew Cab and SUV's only; Tape off these extra wires otherwise.

Remove plastic trim on door near mirror attachment.

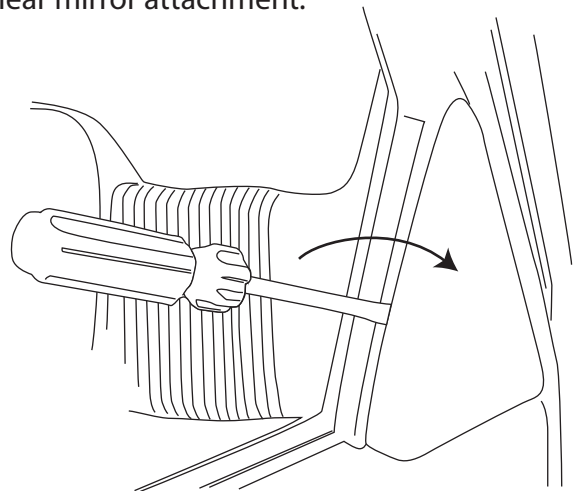

22

To remove door, first pry off door lock tab. Remove door bolts.

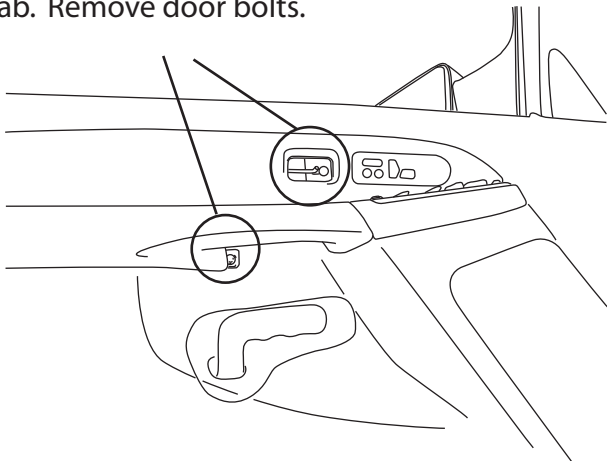

23

Pry off door handle plate and any remaining panel fasteners. Then remove door panel.

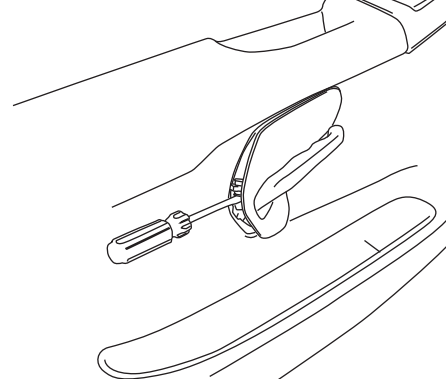

NOTE: Remove door light while removing door panel.

24

INSTALLATION GUIDE

Pull back the door weather guard. Pry off speaker and unplug. Thread plastic tube through accordion.

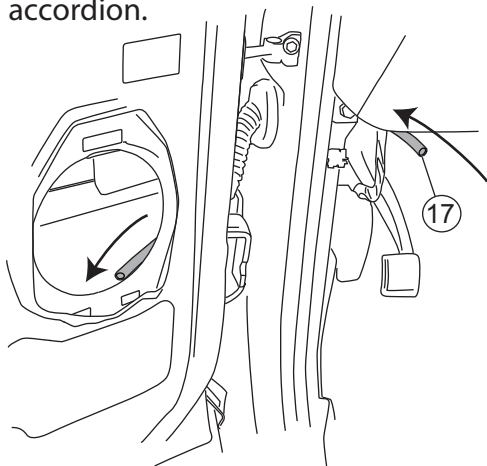

25

Feed longer wire of Step 19 through tube into door and pull out plastic tube on door side.

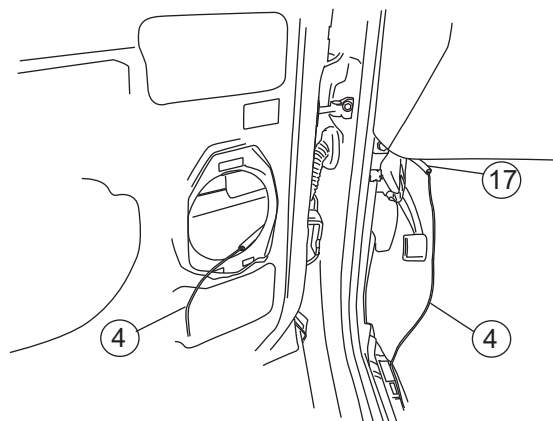

26

Route wire along harness going to switch plate.

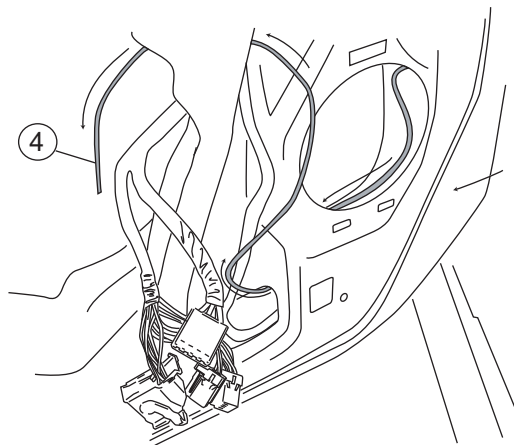

27

Using supplied Posi-Taps™ splice trigger wire into door ajar wire (Driver side: Gray with Black Stripe; Passenger side: Black with White Stripe). The wire leads to the connector with a cam-release lever.

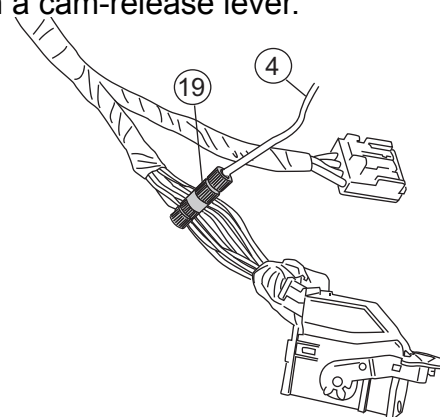

28

Secure all wires with zip ties and electrical tape.

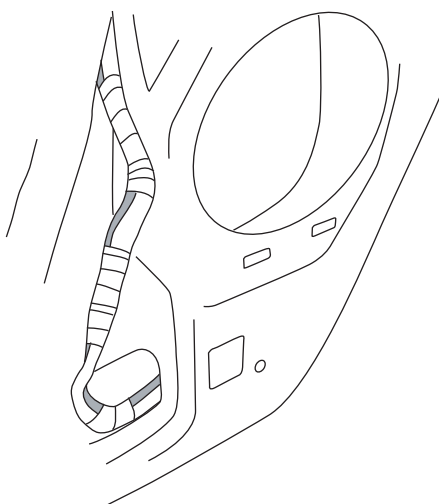

29

Make sure that plug lever is fully opened before reinstalling. Failure to do this will adversely affect the operation of the powerstep and window controls.

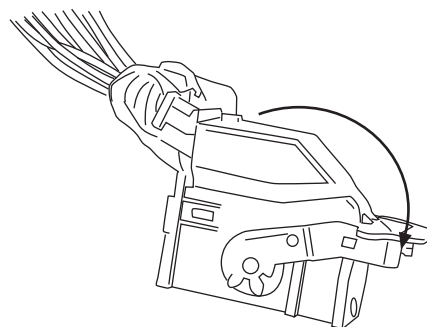

30 Reinstall door panel.

Replace power fuse.

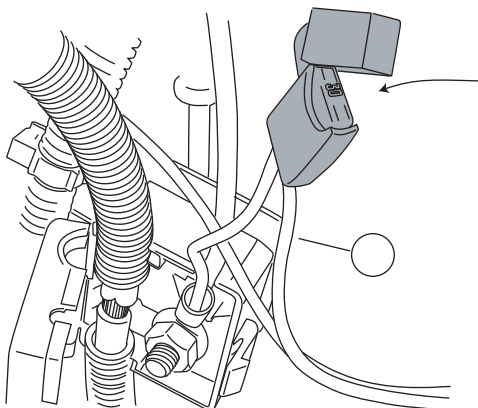

31

Check that both doors activate the powerstep. Reinstall any remaining trim panels. Repeat the adjustments of Step 12 if the stowed step position is not even.

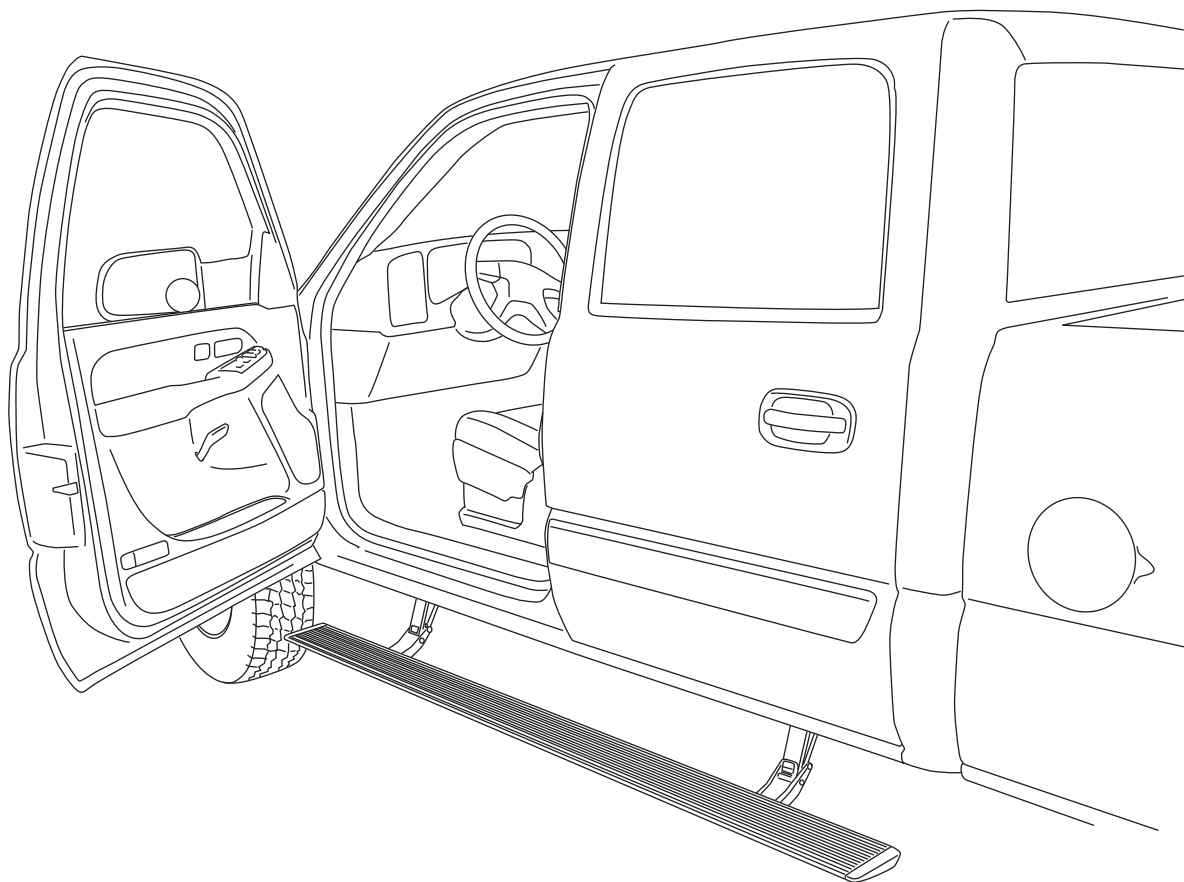

32

Wiring Instructions

GM POWERSTEP ('03-'05) Truck and SUV

DRIVER SIDE

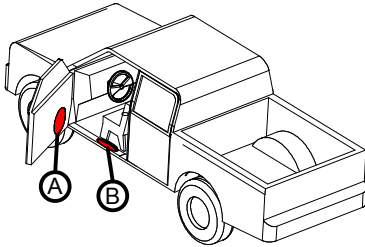

PASSENGER SIDE

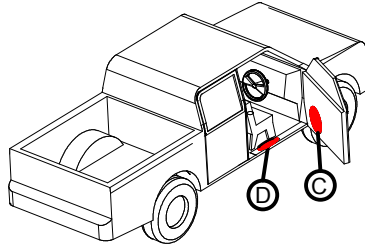

Insulated Spade Connector 

T-Tap Connector 

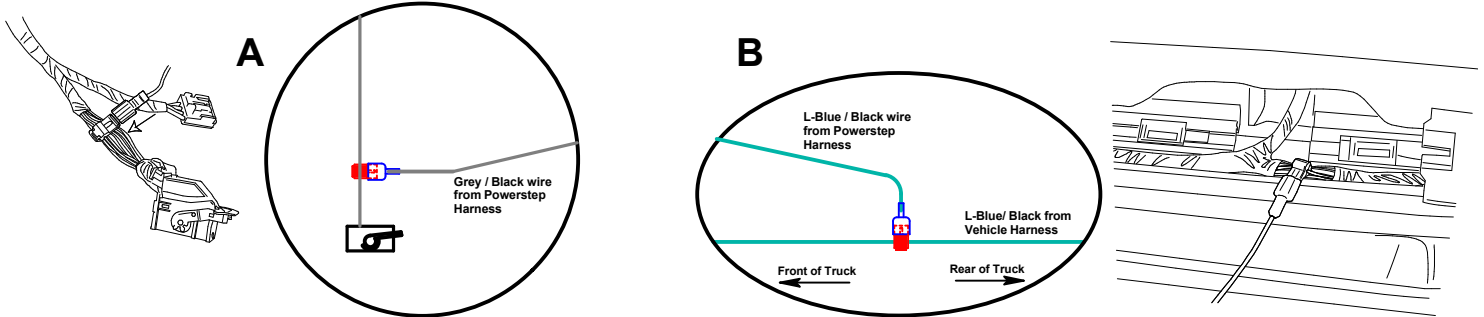

DRIVER SIDE WIRING

1. After removing the front door step plate, lift carpet and pull Powerstep trigger wires through floor of truck.
2. Open wire bundle located under front door step plate and locate the 18Ga. rear door-ajar signal wire (**light blue with a black stripe**).
3. Apply T-Tap connector to the above found wire. Make sure that the T-Tap latches completely.
4. Attach shorter trigger wire of step-1 to spade connector then attach spade to T-tap. Make sure that the spade is center within the insulation before attaching to the T-tap connector.

5. After removing the door panel, you will access the wire bundle at the black cam-plug from window control panel (Area-A). Undo wire wrap and locate the 18Ga. door-ajar signal wire (**grey with a black stripe**).
6. Apply T-Tap connector to the above found wire. Make sure that the T-Tap latches completely.
7. The longer of the two wires from step-1 will be routed to the door panel through front door accordian. Attach routed wire from Powerstep harness to spade connector then attach spade to T-tap. Make sure that the spade is center within the insulation before attaching to the T-tap connector.

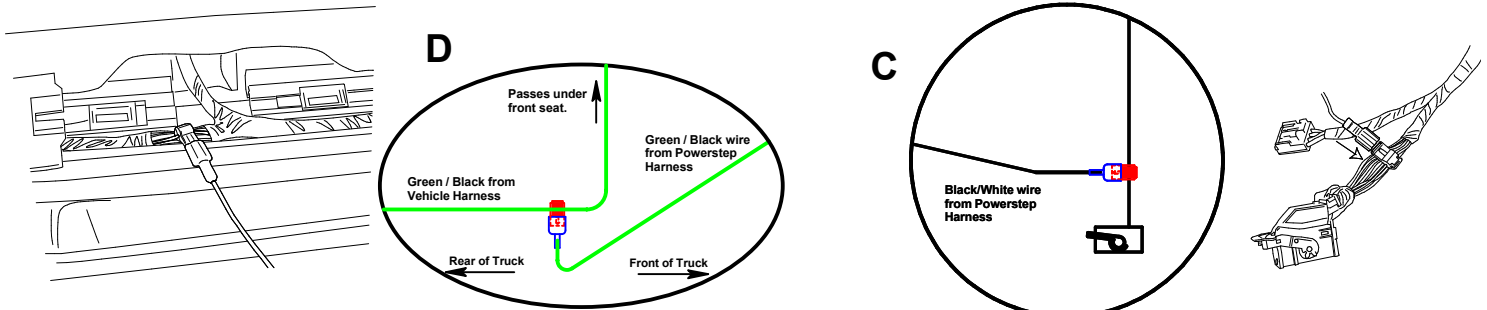

PASSENGER SIDE WIRING

1. After removing the front door step plate, lift carpet and pull Powerstep trigger wires through floor of truck.
2. Open wire bundle located under front door step plate and locate the 18Ga. rear door-ajar signal wire (**green with a black stripe**).
3. Apply T-Tap connector to the above found wire. Make sure that the T-Tap latches completely.
4. Attach shorter trigger wire of step-1 to spade connector then attach spade to T-tap. Make sure that the spade is center within the insulation before attaching to the T-tap connector.

5. After removing the door panel, you will access the wire bundle at the black cam-plug from window control panel (Area -C). Undo wire wrap and locate the 18Ga. door-ajar signal wire (**black with a white stripe**).
6. Apply T-Tap connector to the above found wire. Make sure that the T-Tap latches completely.
7. The longer of the two wires from step-1 will be routed to the door panel through front door accordian. Attach routed wire from Powerstep harness to spade connector then attach spade to T-tap. Make sure that the spade is center within the insulation before attaching to the T-tap connector.

Notes:

1. All of the signal wires tapped into will be 18Ga. Do not tap into anything with a thicker gage than this.
2. Occasionally the wire colors do not match the wire schematics. Under these circumstances you will need to locate the door-ajar signal wires.
3. Make sure to secure all wires after install. Loose wires can be damaged and may cause a failure in the Powerstep's function.

Wiring Instructions

GM POWERSTEP 1999-2002 Truck & SUV - LUXURY & UP LEVEL

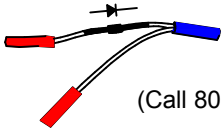

Single Diode Harness - Qty: 4
(Call 800-315-9705 to receive diodes free of charge.)

ATTENTION: Pay close attention to the orientation of the diode harnesses. The Power-Step will not work with a incorrectly installed diode harness.

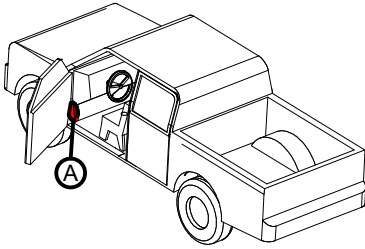

Figure A-1

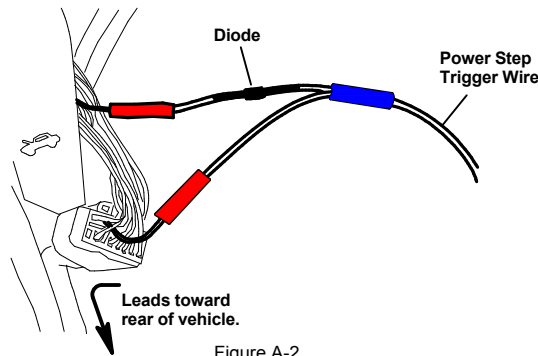

Figure A-2

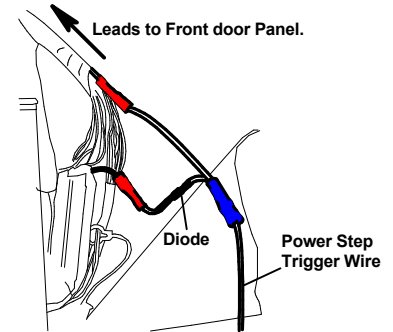

Figure A-3

DRIVER SIDE WIRING

1. After removing the front door step plate and kick plate, lift carpet and pull Powerstep trigger wires through floor of truck.
2. Locate the rear door-ajar signal wire (**dark blue with white stripe**) on black connector below the hood-release lever (Area-A in Figure A-1). There should be two wires of this color; use the wire located on the row closest to the plug release.
3. Cut this wire and install Single Diode Harness as oriented in Figure A-2.
4. After trimming to correct length, connect the light blue with black stripe trigger wire from step one to the blue connector of Single Diode Harness installed in previous step.

5. Locate the front door-ajar signal wire (**tan**) on large connector located behind the connector of step 2.
6. Cut this wire and install Single Diode Harness as oriented in Figure A-3.
7. After trimming to correct length, connect the grey with black stripe trigger wire from step one to the blue connector of Single Diode Harness installed in previous step.
8. Wrap all connections with electrical tape and secure any loose wires.

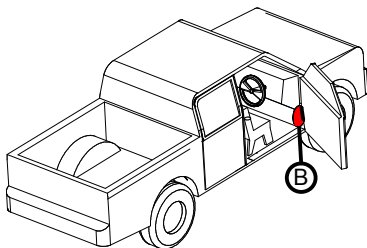

Figure B-1

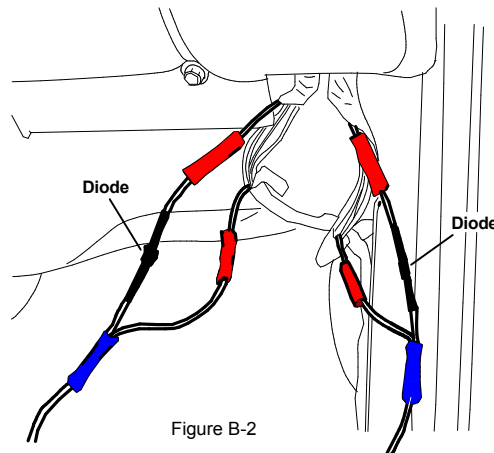

Figure B-2

PASSENGER SIDE WIRING

1. After removing the front door step plate, lift carpet and pull Powerstep trigger wires through floor of truck.
2. Locate the two wire bundles running up along kick panel area underneath glove compartment as shown in the above figures.
3. Open wire wrap of the bundles and locate the front and rear door-ajar signal wires (**dark blue with white stripe**), one found in each bundle.

4. Cut each wire and install the Single Diode Harnesses as oriented in Figure B-2. Make certain that the leg with the diode is towards the top.
5. Wrap all connections with electrical tape and secure any loose wires.

Notes:

1. All of the signal wires tapped into will be 18Ga. Do not tap into anything with a thicker gage than this.
2. Occasionally the wire colors do not match the wire schematics. Under these circumstances you will need to locate the door-ajar signal wires.
3. Make sure to secure all wires after install. Loose wires can be damaged and may cause a failure in the Powerstep's function.

Wiring Instructions

GM POWERSTEP 1999-2002 Truck & SUV - BASE LEVEL

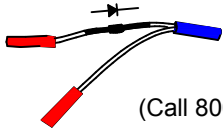

Single Diode Harness - Qty: 4
(Call 800-315-9705 to receive diodes free of charge.)

ATTENTION: Pay close attention to the orientation of the diode harnesses. The Power-Step will not work with a incorrectly installed diode harness.

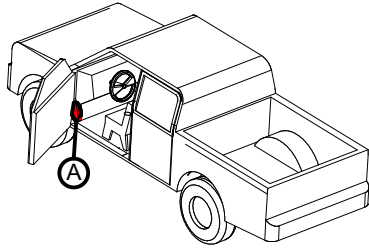

Figure A-1

DRIVER SIDE WIRING

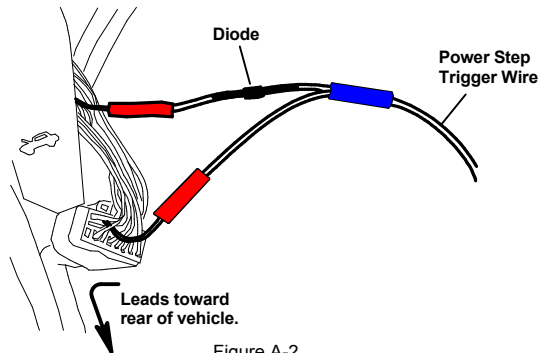

Figure A-2

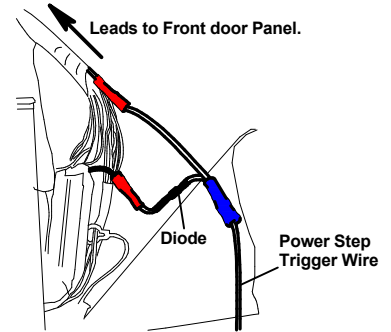

Figure A-3

1. After removing the front door step plate and kick plate, lift carpet and pull Powerstep trigger wires through floor of truck.
2. Locate the rear door-ajar signal wire (**orange**) on black connector below the hood-release lever (Area-A in Figure A-1). There should be two wires of this color; use the wire located on the row closest to the plug release.
3. Cut this wire and install Single Diode Harness as oriented in Figure A-2.
4. After timing to correct length, connect the light blue with black stripe trigger wire from step one to the blue connector of Single Diode Harness installed in previous step.

5. Locate the front door-ajar signal wire (**tan**) on large connector located behind the connector of step 2.
6. Cut this wire and install Single Diode Harness as oriented in Figure A-3.
7. After timing to correct length, connect the grey with black stripe trigger wire from step one to the blue connector of Single Diode Harness installed in previous step.
8. Wrap all connections with electrical tape and secure any loose wires.

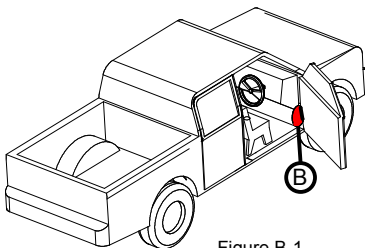

Figure B-1

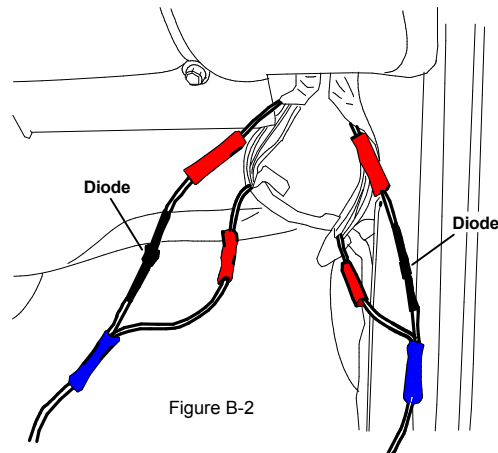

Figure B-2

PASSENGER SIDE WIRING

1. After removing the front door step plate, lift carpet and pull Powerstep trigger wires through floor of truck.
2. Locate the two wire bundles running up along kick panel area underneath glove compartment as shown in the above figures.
3. Open wire wrap of the bundles and locate the front and rear door-ajar signal wires (**dark blue with white stripe**), one found in each bundle.

4. Cut each wire and install the Single Diode Harnesses as oriented in Figure B-2. Make certain that the leg with the diode is towards the top.
5. Wrap all connections with electrical tape and secure any loose wires.

Notes:

1. All of the signal wires tapped into will be 18Ga. Do not tap into anything with a thicker gage than this.
2. Occasionally the wire colors do not match the wire schematics. Under these circumstances you will need to locate the door-ajar signal wires.
3. Make sure to secure all wires after install. Loose wires can be damaged and may cause a failure in the Powerstep's function.

Wiring Instructions

GM POWERSTEP 1999-2002 Sierra Denali Only

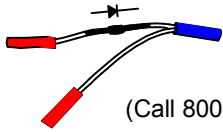

Single Diode Harness - Qty: 4

(Call 800-315-9705 to receive diodes free of charge.)

ATTENTION: Pay close attention to the orientation of the diode harnesses. The Power-Step will not work with a incorrectly installed diode harness.

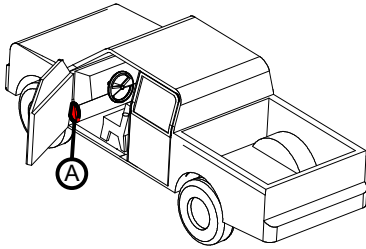

Figure A-1

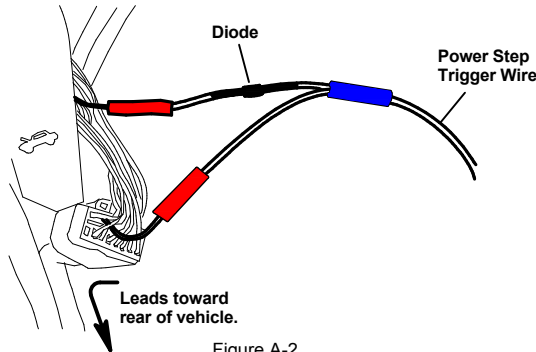

Figure A-2

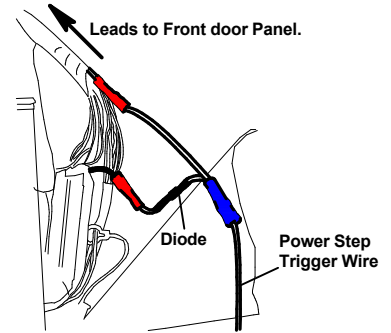

Figure A-3

DRIVER SIDE WIRING

1. After removing the front door step plate and kick plate, lift carpet and pull Powerstep trigger wires through floor of truck.
2. Locate the rear door-ajar signal wire (**dark blue with white stripe**) wire on black connector below the hood-release lever (Area-A in Figure A-1). There should be two wires of this color; use the wire located on the row closest to the plug release.
3. Cut this wire and install Single Diode Harness as oriented in Figure A-2.
4. After trimming to correct length, connect the light blue with black stripe trigger wire from step one to the blue connector of Single Diode Harness installed in previous step.

5. Locate the front door-ajar signal wire (**light green with black stripe**) on large connector located behind the connector of step 2.
6. Cut this wire and install Single Diode Harness as oriented in Figure A-3.
7. After trimming to correct length, connect the grey with black stripe trigger wire from step one to the blue connector of Single Diode Harness installed in previous step.
8. Wrap all connections with electrical tape and secure any loose wires.

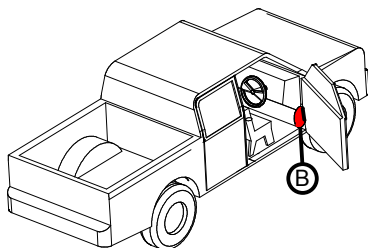

Figure B-1

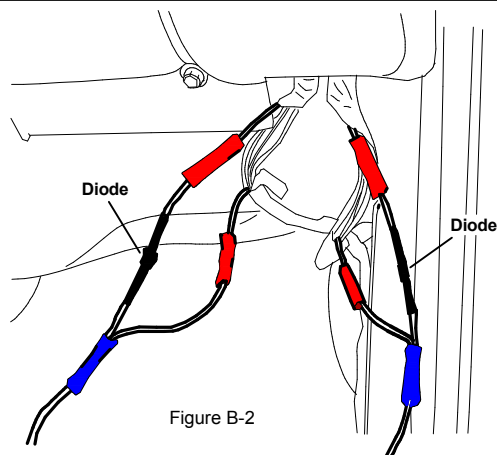

Figure B-2

PASSENGER SIDE WIRING

1. After removing the front door step plate, lift carpet and pull Powerstep trigger wires through floor of truck.
2. Locate the two wire bundles running up along kick panel area underneath glove compartment as shown in the above figures.
3. Open wire wrap of the bundles and locate the rear door-ajar signal wire (**dark blue with white stripe**) in one bundle and the front door-ajar signal wire (**light green with black stripe**) in the other bundle.

4. Cut each wire and install the Single Diode Harnesses as oriented in Figure B-2. Make certain that the leg with the diode is towards the top.
5. Wrap all connections with electrical tape and secure any loose wires.

Notes:

1. All of the signal wires tapped into will be 18Ga. Do not tap into anything with a thicker gage than this.
2. Occasionally the wire colors do not match the wire schematics. Under these circumstances you will need to locate the door-ajar signal wires.
3. Make sure to secure all wires after install. Loose wires can be damaged and may cause a failure in the Powerstep's function.

Congratulations on the purchase of your AMP Research Power Step



Here's what you should know...

OPERATION

The AMP Research Power Step automatically deploys when at least one door opens and automatically retracts under your vehicle when both front and rear doors close. If resistance or blockage is encountered while the Power Step is in motion, the drive system is designed to automatically stop. To reset, simply open or close the vehicle door and the Power Step will resume normal operation.

MAINTENANCE TIPS

The stepping surface and drive mechanism can be wash with mild soap and water using a soft brush or sponge to dislodge any mud, dirt or accumulated road grime. Rinse with fresh water.

To prevent slipping, avoid applying waxes, lubricants or protectants like Armor All® to the step surface.

When washing your vehicle, the Power Steps can be set to remain deployed with the doors closed for easy cleaning. Do this...

- 1** With the Power Step deployed, press and hold the board down with your foot.
- 2** Close the door while continuing to press down the board. (This will not harm motor.)
- 3** To reset the Power Step, simply open and close the door. (Repeat for both sides of vehicle.)

CAUTION! BE SURE TO KEEP HANDS AWAY WHEN THE POWER STEP IS IN MOTION.

amp-research.com

LIMITED WARRANTY

AMP RESEARCH warrants product to be free from defects in material and workmanship, for terms specified below, provided there has been normal use and proper maintenance. All remedies under this warranty are limited to the repair or replacement of any item found by the factory to be defective within the time period specified.

If you have a warranty claim, first you must call our factory at the number below for instructions. You must retain proof of purchase and submit a copy with any items returned for warranty work. Upon completion of warranty work, if any, we will return the repaired or replaced item or items to you freight prepaid. Damage to our products caused by accidents, fire, vandalism, negligence, misinstallation, misuse, Acts of God, or by defective parts not manufactured by us, is not covered under this warranty.

THE WARRANTY TIME PERIOD IS AS FOLLOWS: 5-YEARS FROM DATE OF PURCHASE.

ANY IMPLIED WARRANTIES OF MERCHANTABILITY AND/OR FITNESS FOR A PARTICULAR PURPOSE CREATED HEREBY ARE LIMITED IN DURATION TO THE SAME DURATION AND SCOPE AS THE EXPRESS WRITTEN WARRANTY. OUR COMPANY SHALL NOT BE LIABLE FOR ANY INCIDENTAL OR CONSEQUENTIAL DAMAGE.

Some states do not allow limitations on how long an implied warranty lasts, or the exclusion or limitation of incidental or consequential damages, so the above limitations or exclusions may not apply to you. This warranty gives you specific legal rights, and you may also have other rights that vary from state to state.

WARNING

Be sure to read and precisely follow the provided instructions when installing this product. Failure to do so could place the vehicle occupants in a potentially dangerous situation. After installing or reinstalling, re-check to insure that the product is